

Radio Merit Badge

Boy Scouts of America



Module 2 – Electronics & Safety

2005

Key Topics in This Module

- **How Radio Carries Information**
- **Block Diagrams of Radios**
- **Schematic Diagrams**
- **Electronic Components & Symbols**
- **Conductors & Insulators**
- **Types of Electrical Circuits**
- **Radio Safety**

Continuous Wave (CW)

The Oldest Digital Mode

Works by simply turning the transmitter on and off in a pattern called Morse Code.

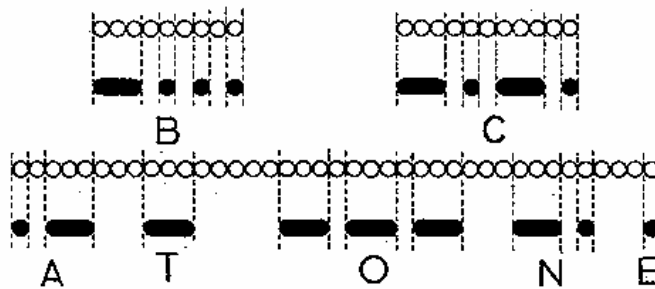

Diagram illustrating relative lengths of dashes and spaces referred to the duration of a dot. A dash is exactly equal in duration to three dots; spaces between parts of a letter equal one dot; those between letters, three dots; space between words, five dots. Note that a slight increase between two parts of a letter will make it sound like two letters.

“CW” or Morse Code

No longer required for the Radio Merit Badge, but still popular among ham radio operators. Some higher class FCC licenses still require one to be able to send and receive Morse Code.

A	•—	N	—••	1	•—•—•—•—
B	—•••	O	—•—•—	2	••—•—•—
C	—•—•—•	P	••—•—•	3	••••—•—
D	—•••	Q	—•—•—•	4	•••••—
E	•	R	•—••	5	•••••
F	••—••	S	•••	6	—••••
G	—•—•	T	—	7	—•—••
H	••••	U	••—	8	—•—•••
I	••	V	••••	9	—•—•—•
J	•—•—•—	W	—•—•	0	—•—•—•—
K	—•—•	X	—••••		
L	•—•••	Y	—•—•—•		
M	—•—•	Z	—••••		
PERIOD (.)	•••••••	WAIT SIGN (AS)	•••••		
COMMA (,)	—•—•—•—	DOUBLE DASH (BREAK)	—•—•—		
INTERROGATION (?)	••—•—•••	ERROR (ERASE SIGN)	•••••••		
QUOTATION MARK (")	—•—•—••	FRACTION BAR (/)	—•—•—•		
COLON (:)	—•—•—•••	END OF MESSAGE (AR)	••—•—••		
SEMICOLON (;)	—•—•—•••	END OF TRANSMISSION (SK)	•••••••		
PARENTHESIS ()	—•—•—•••	INTERNAT. DISTRESS SIG. (SOS)	•••—•—•—•—•—•—•—		

Ø MEANS ZERO, AND IS WRITTEN IN THIS WAY TO DISTINGUISH IT FROM THE LETTER "O". IT OFTEN IS TRANSMITTED INSTEAD AS ONE LONG DASH (EQUIVALENT TO 5 DOTS).

Figure 1

The Continental (or International Morse) Code is used for substantially all non-automatic radio communication. DO NOT memorize from the printed page; code is a language of SOUND, and must not be learned visually; learn by listening as explained in the text.

How do Radio Waves Carry Sounds or Information?

FM



©2000 How Stuff Works

AM

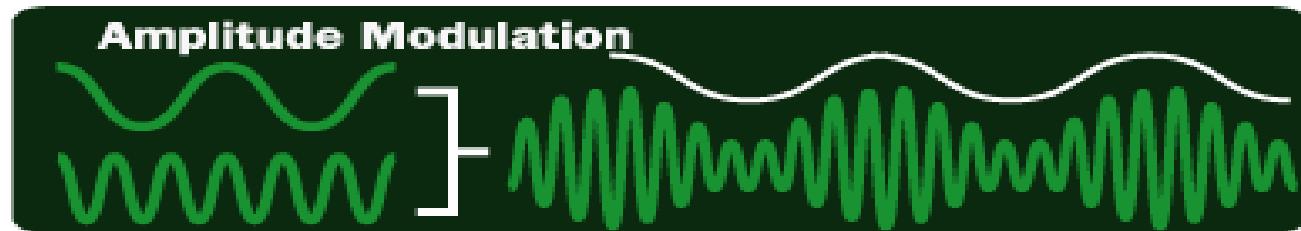

©2000 How Stuff Works

PM



©2000 How Stuff Works

How Radios Send and Receive Information

- **Microphone**
 - Audio or Digital signal input
- **Transmitter**
 - Creates the RF “carrier”
 - Modulates the carrier
- **Amplifier**
 - Increases RF signal power
- **Tuner**
 - Matches transmitter to antenna
- **Feed line**
 - Provides path to antenna
- **Antenna**
 - Radiates RF signal
- **Key or Paddle**
 - For sending Morse code

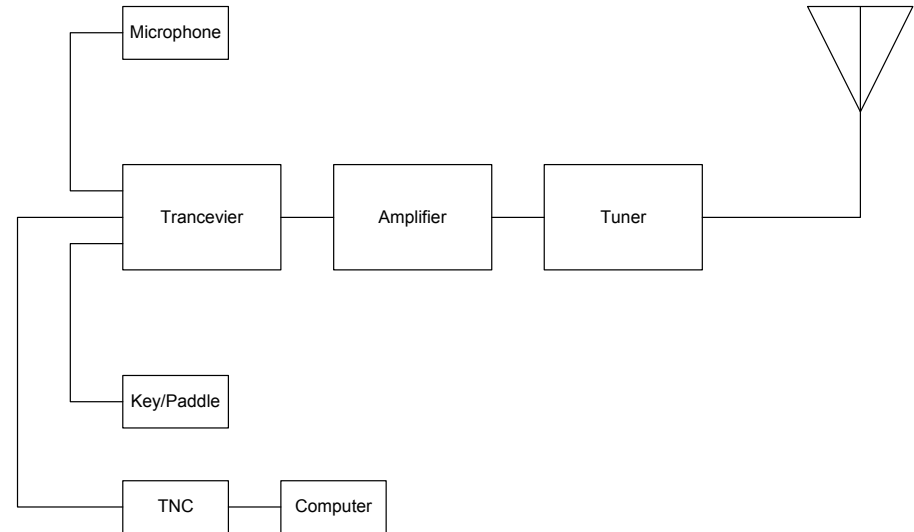

Simplified Block Diagram

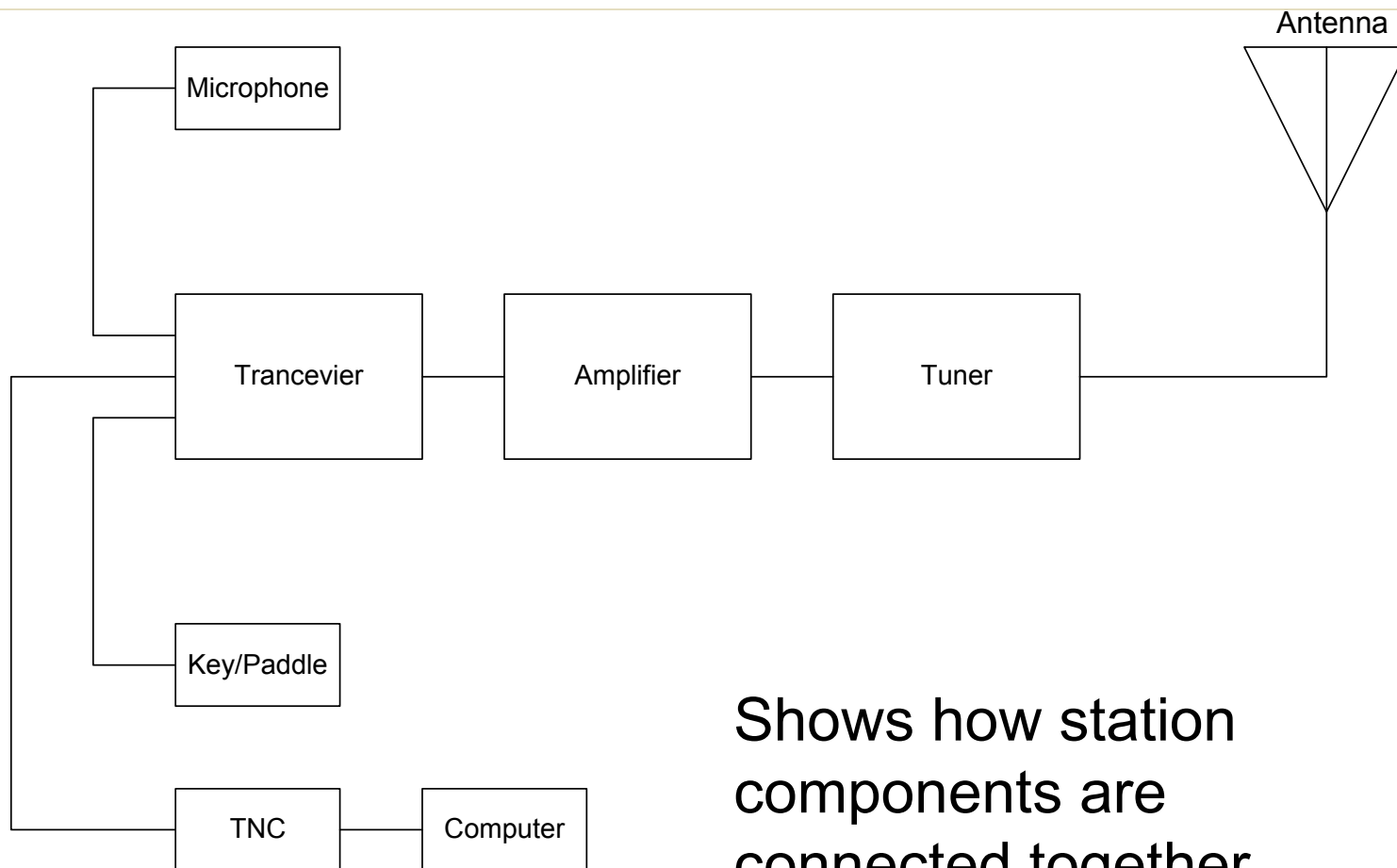

Shows how station components are connected together.

Detailed Block Diagram

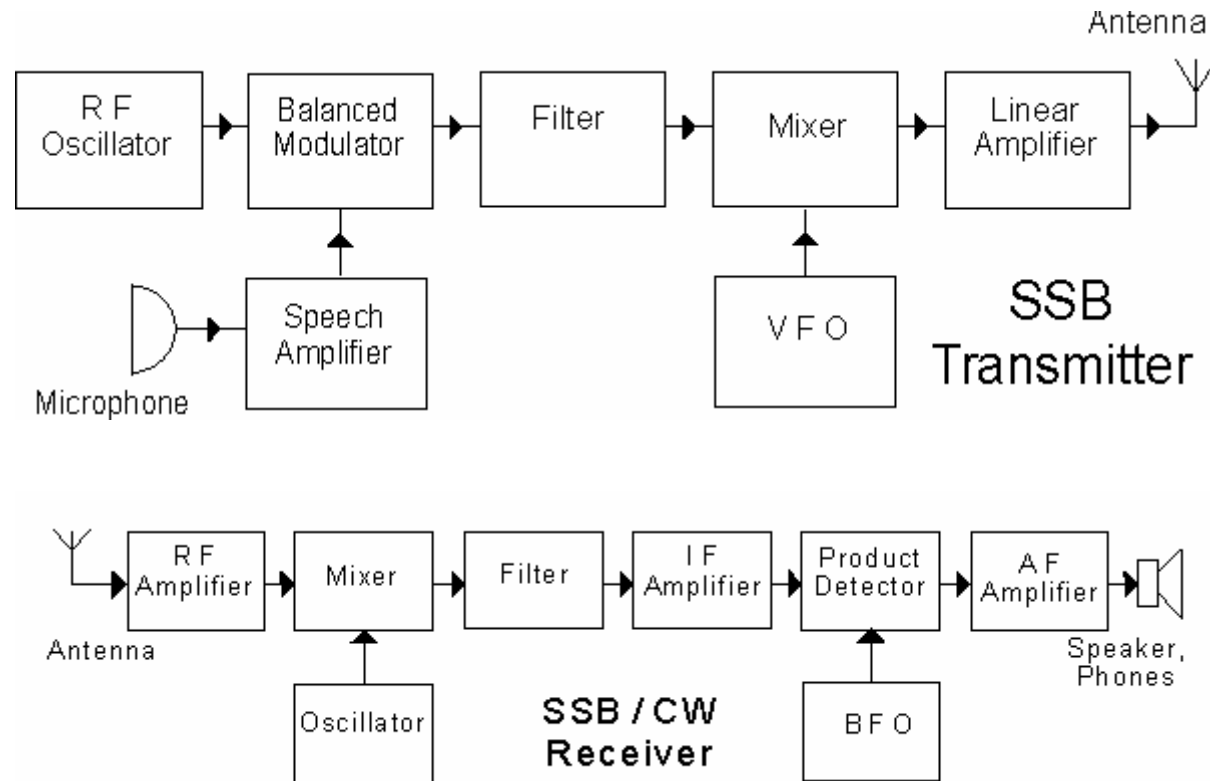

Shows how the radio works.

Schematic Diagram

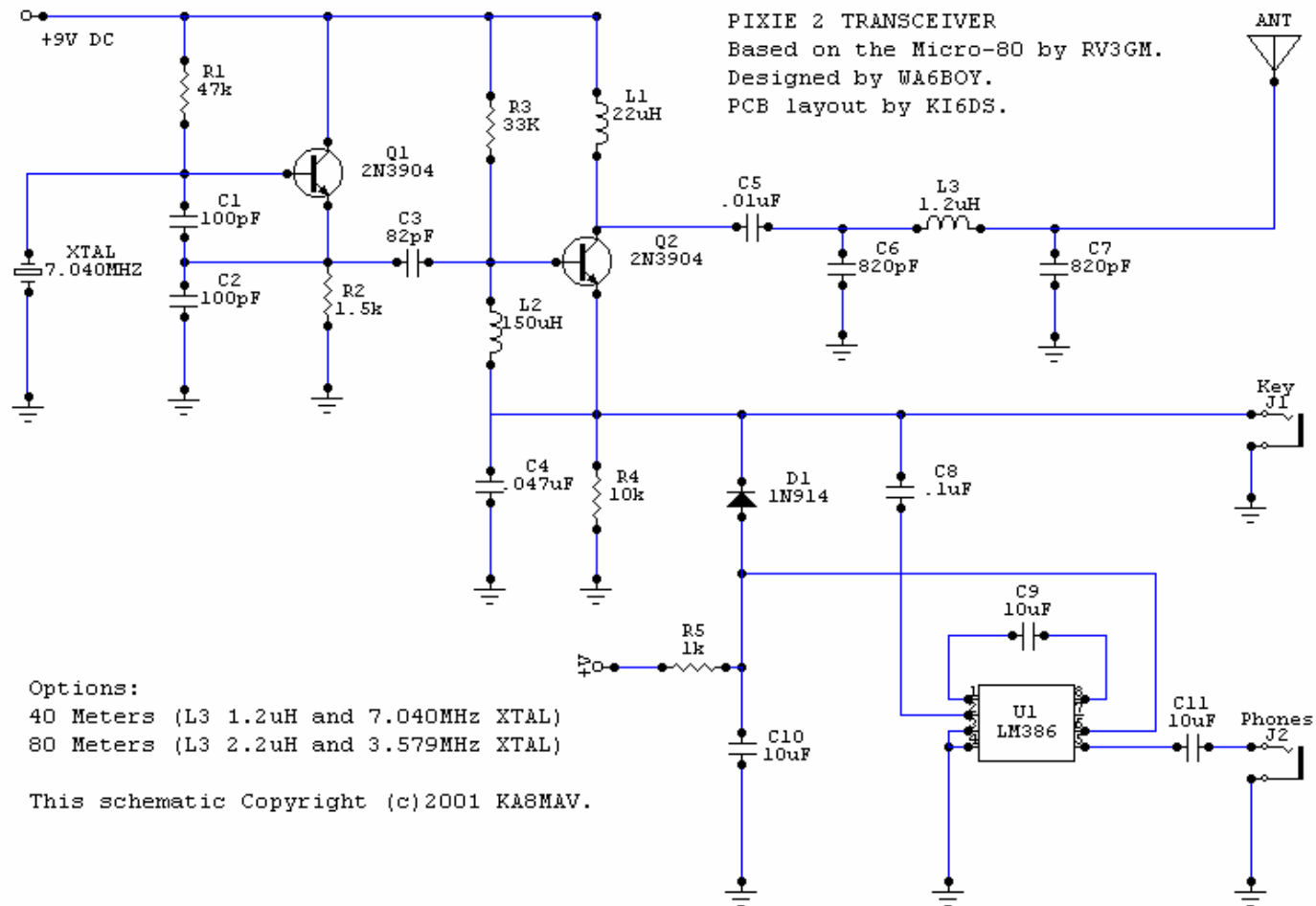

Shows how to build a radio from components.

Schematic Symbols

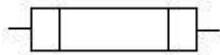

Fuse

Contains a thin wire which is made to melt which protects the rest of the circuit from damage if there is too much current from a short circuit.



Battery

Stores electric energy.



Resistor

Resists the flow of electric current, reducing its flow.

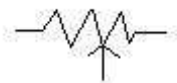

Variable resistor

Like a regular resistor, but adjustable. For example, the volume knob on your stereo.

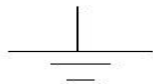

Earth ground

A connection between the equipment (radio) and the earth, usually through a copper pipe driven into the soil.

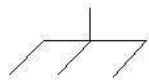

Chassis ground

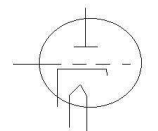
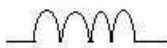
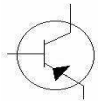
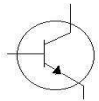
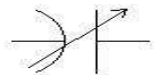
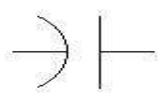

A connection of the negative side of the electronic circuit to the chassis, or steel frame, of the equipment.

Schematic Symbols (cont.)



Capacitor	Gets and stores an electric charge. Lets alternating current (AC - like in your house) flow but stops direct current (DC - like from a battery).
Variable capacitor	Same as a regular capacitor, but adjustable.
NPN transistor	Amplifies a current.
PNP transistor	Amplifies a current.
Coil	Also called a choke, it works the opposite of a capacitor. It lets DC flow but stops AC.
Tube	A vacuum tube made of glass with wire filaments inside. Amplifies a current. It has been replaced by transistors in most home equipment, but is still found in some high power radio transmitters.

Schematic Symbols (cont.)

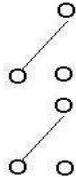
	Antenna	Sends radio frequency signals into the air.
	SPST switch	Single-pole single-throw switch. Has two positions, on and off. Like most light switches
	DPDT switch	Double-pole double-throw switch. A double-throw switch has three positions. It can switch one input to one of two outputs - sort of like the switch you put on your television to switch between watching TV and playing your video game. The double-pole means it can switch a pair of inputs to either of two pairs of outputs.

Conductors & Insulators

- **Conductors** conduct (carry) electricity.
 - Most Metals (Gold, Silver, Aluminum, Copper)
 - Many Liquids (Water)
- **Insulators** insulate (don't carry) electricity.
 - Air
 - Most Rubbers and Plastics
 - Most Ceramics
 - Wood and cloth (when dry)

Types of Electrical Circuits

Closed Circuit

- Circuit is complete.
- Electricity flows like it should.

Open Circuit

- Circuit is incomplete.
- Electricity doesn't flow.

Short Circuit

- Circuit is complete through an unplanned shortcut.
- Electricity flows where it shouldn't!
- Dangerous – parts can get hot, start fires or even explode!

Radio Safety

- Electrical shock can hurt or kill - make sure the power is disconnected before working.
- Even with the power off, some parts inside the radio can hold a dangerous charge. If you don't know what you are doing, get help.
- Radio Frequency (RF) can burn - keep antennas out of reach .
- Strong RF radiation can be unhealthy - Don't use a radio when it is not completely assembled. The case keeps the RF radiation in.
- Make sure antennas can't touch any power lines or you could be electrocuted when using the radio.
- Lightning can hit your antenna and travel down your lines to the radio. Make sure your antenna and radio are grounded to a good earth ground.
- Be careful working on towers and roofs so you don't fall or hurt someone on the ground.